



FireMaster[®] Flexible Wrap System

Structural Steel Fire Protection



FireMaster® Marine Plus

Flexible wrap system for structural steel fire protection

Cellulosic and Hydrocarbon fire insulation to steel beams and columns

The FireMaster structural steel fire protection system provides insulation to steel beams and columns to ensure they maintain their load-bearing capacity when exposed to fire, thus preventing collapse of the structure. The system consists of a non-combustible, flexible, insulating blanket which is wrapped around the exterior profile of structural steel sections and held in place using welded steel pins and friction fit washers.



FireMaster Marine Plus is flexible so it can easily wrap around the outer profile of I beams and columns. FireMaster Marine Plus can be applied in one or two layers depending on the steel section factor, required critical temperature and the fire protection time rating required.

The system is classified for fire protection in the range of R30 to R180 in accordance with EN 13501-2 based on fire testing to 13381-4: 2013 standard, the product and system has a European CE mark (ETA-20/1296) in accordance with EAD 350142-00-1106 for Fire protective board, slab and mat products and kits and is also certified by Lloyds for use in Marine & Offshore applications.



No Specialized Equipment Needed

Flexible wrap system ideal for maintenance applications



Fast and Easy Installation

Quick installation using welded pins



Adapts to Complex Shapes

Wraps tightly around intricate steel profiles



Low Waste & Lightweight

Minimal cutting, low added weight

SLIM · SIMPLE · QUICK

FIREMASTER®

Design Considerations for Structural Steel Fire Protection

The insulation thickness required for structural steel fire protection depends on several key design factors, including the fire exposure duration, the critical temperature of the steel, and the section factor of the steel member.

Critical steel temperature

The purpose of fire protection is to help steel elements maintain their load-bearing performance by keeping the steel temperature below a specified limit during a fire. This critical temperature is typically defined by the project's structural fire design requirements and applicable building regulations. As a general reference, commonly adopted design temperatures are 550°C for columns and 620°C for beams supporting concrete floors.

Section Factor

Another important consideration is the section factor, which reflects how quickly a steel section will heat up in fire conditions. It is based on the relationship between the surface area exposed to fire and the amount of steel available to absorb heat. In general, steel sections with a higher section factor heat up more quickly and may require greater insulation thickness to achieve the same fire resistance period.

By considering these factors together, the fire protection system can be designed to deliver the required level of performance while supporting efficient and practical application

Case Study

Key Design features of the system

Fire Protection periods	30 to 180 minutes
Steel Critical temperature range	150°C to 700°C
Steel preparation required	None
Number of layers allowed	Single layer (maximum thickness 52mm) or two layers (minimum thickness 60mm)
Installation Method	For H beams the outer profile of the section is wrapped
May be installed on	Beams, columns, hollow sections, sections with re-entrant details (e.g. channels, angles, tees)

The example, below, compares the section factors of two different sized steel columns.

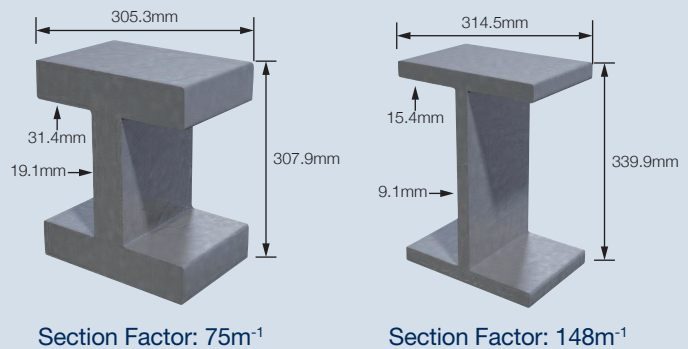

Section Factor	Insulation thickness required to maintain steel temperature of ≤ 550°C for two hours when exposed to cellulosic fire conditions
75m ⁻¹	28mm (Single layer)
148m ⁻¹	50mm (Single layer)







Typical Applications

Flexible wrap systems are particularly advantageous for irregular shapes, congested areas, and retrofit applications, where traditional rigid fire protection methods are difficult to install.

- Primary and secondary steel beams
- Columns
- Tubular steel sections
- Connections and nodes
- Plantroom and back-of-house steel
- Retrofit and refurbishment steel upgrades



Commonly used across a wide range of sectors, including:

-  Data centres
-  Modular semiconductor facilities
-  Car park
-  Critical infrastructure (e.g. railways, fuel depots)
-  Warehouse buildings
-  Manufacturing facilities and plantrooms



Talk to Our Fire Protection Specialists

Get in touch today to discuss your project requirements, request technical support, or explore the most effective FireMaster® solution for your steel protection needs.

FIREMASTER®

For all enquiries, please contact our specialist sales and marketing offices:

Americas

marketing.tc@morganplc.com

Asia

asiasales@morganplc.com

Europe

sales.tcemea@morganplc.com

Thermal Ceramics is a business of Morgan Advanced Materials

www.morganadvancedmaterials.com
www.morganthermalceramics.com