

Morgan Advanced Materials

Significant trends shape our modern world, accelerating the demand for new and more sustainable advanced materials.

At Morgan Advanced Materials, we use advanced carbon and ceramics materials to support the move to a more sustainable world. Our people are driven to solve complex customer problems: from managing heat and enabling greener technologies, to supporting improved medical diagnostics and protecting life.

Our purpose is 'to use advanced materials to make the world more sustainable, and to improve the quality of life'. This purpose is underpinned by our safe, ethical and inclusive culture, embraced by our 7,800 employees spanning over 25 countries. Working across many industries and in a number of markets, we deliver the materials science and technologies the world needs now.

Our Strategy

We are a global advanced manufacturing organisation with leading capabilities in three areas: materials science, application engineering and customer focus.

Our Business Model

We operate as two global divisions and five global business units. We empower our global business unit teams, giving them considerable autonomy and enabling them to act quickly and support their customer needs. Our broad manufacturing footprint enables us to supply customers locally from a short supply chain.

www.morganthermalceramics.com
www.morganadvancedmaterials.com

Morgan Advanced Materials plc
Quadrant, 55-57 High Street
Windsor, Berkshire, SL4 1LP
United Kingdom

For all enquiries, please contact our specialist sales and marketing offices

Americas

marketing.tc@morganplc.com

Asia

asiasales@morganplc.com

EMEA

sales.tcemea@morganplc.com



Morgan Advanced Thermal Management Solutions

Pipe Insulation

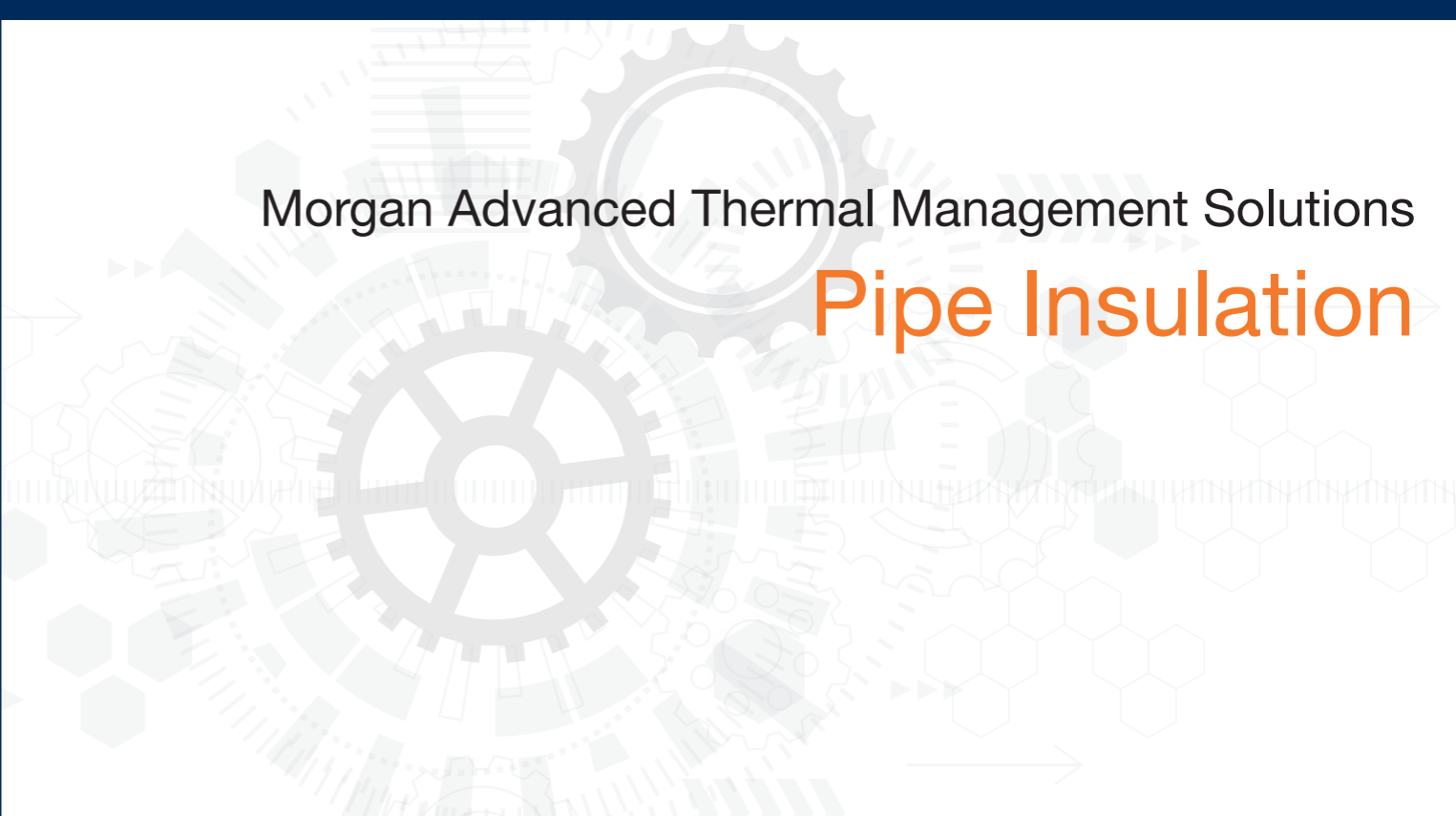

THERMAL CERAMICS

High-performance thermal management applications worldwide

REDUCE HEAT LOSS • SAVE ENERGY • REDUCE CARBON EMISSION

As a world leader in thermal management, Thermal Ceramics creates value with innovative thermal products and systems to help customers reduce heat loss, energy consumption, and operating costs, resulting in reduced CO₂ emissions for a more sustainable operational footprint.

We have extensive experience working with customers all over the world to engineer, design and install high-performance insulation in operating environments from ambient to 1750°C.

We also research, develop and manufacture a broad range of thermal insulation products and systems, offering total insulation product packages and optimal lining solutions.

- Fibres
- Refractory – monolithics, insulating fire bricks, structural blocks
- Microporous

Global Footprint

We have a truly global footprint to serve our customers better worldwide.

- 20 manufacturing facilities in 12 countries in 5 continents
- 26 sales and engineering offices
- Fibre Centre of Excellence in UK with Technology Centers in all regions

We are committed to environmental sustainability through our product development programs and strive to minimize our operations' impact on the environment.

Thermal Ceramics is a trusted, end-to-end thermal management partner globally



Why Morgan for Pipe Insulation?

We deliver integrated thermal management solutions—combining engineering expertise, a comprehensive product portfolio, and global application support.



Safe and Reliable Products

Trusted brand that delivers quality, consistency and reliability



Commitment to Innovation

Deep knowledge of thermal management coupled with material science research & development



Flexibility

Optimal lining designs through flexible combinations of broad range of materials

Integrated Pipe Insulation Engineering Process

A structured, five-phase methodology ensuring thermal performance and long-term system integrity across industrial piping applications.

1 Pipe Lining Assessment

Review of required pipe insulation dimensions and thermal profile specification

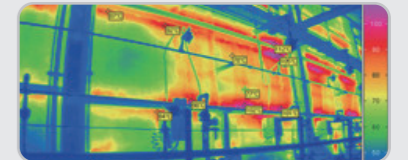

2 Material Selection

Selection of the best material based on experience and expertise and supported by heat flow analysis software

Calculation		New Lining slag line		Units		Units characteristics	
Inside	Outside	mm	mm	°C	mm	mm	mm
Ambient temperature	1600	45		°C	1600	45	°C
Surface temperature	1550.0	325.8		°C	1550.0	325.8	°C
Heat transfer coefficient	150	27.75		W/m ² ·K	150	27.75	W/m ² ·K
Diameter	2400	3227		mm	2400	3227	mm
Well layers from inside to outside		Thickness	Density	Conductivity	Specific heat	Heat capacity	Heat loss
1	NGO-C Brick	230	2600	1.700	1536	1402	0.0
2	SALAMANTE BRICK "B 70"	66	2600	1.740	1281.8	1141	1.632
3	Superwool 8000	13	600	0.030	987.2	700	0.161
							325.8

3 Engineering Design

Incorporate suitable lining hardware design, with accessories and jacket/cladding

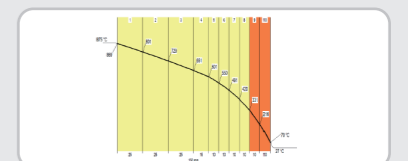

4 Proper Installation & Supervision

Ensure installation in accordance with manuals and correct techniques, supported by supervision services

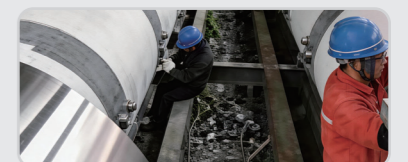

5 Performance Verification / Energy Audits

Infrared (IR) thermography inspection to verify initial design performance

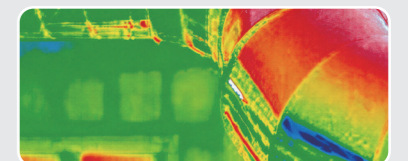

OUR PRODUCTS

Our pipe insulation portfolio, including microporous, aerogel and ceramic fibre technologies, delivers high-performance thermal solutions for industrial piping systems from ambient to high temperatures. Designed to reduce heat loss, improve energy efficiency and enhance process reliability, our materials can be flexibly combined to optimize thermal performance, space constraints and installation requirements for pipes, valves and complex geometries.

 <p>WDS MultiFlex PLUS</p> <p>Flexible quilted microporous insulation, available in hydrophilic and hydrophobic grades. Best-in-class thermal performance with low shrinkage up to 1000°C. Excellent handling, cutting, and twisting properties — ideal for complex geometries.</p>	 <p>Superwool PLUS Blanket</p> <p>Low biopersistent fibre blanket manufactured via patented low-shot technology, with classification temperature of 1200°C. Excellent thermal shock resistance, and ideal for high-temperature applications.</p>	 <p>AEROX GP Blanket</p> <p>Flexible hydrophobic aerogel blanket with a max operating temperature of 650°C. Achieves the same thermal performance as traditional insulation at 1/5 to 1/2 the thickness. Outstanding corrosion under insulation (CUI) protection and space utilization.</p>
--	---	---

Material Comparison at a Glance

Property	WDS® MultiFlex PLUS	Superwool® PLUS Blanket	AEROX® GP Blanket
Max Temp.	~1000°C	1050°C	~650°C
Thickness	Ultra Thin	Moderate	Thin
Conductivity	Lowest	Low	Very low
Flexibility	Flexible panels	Flexible blankets	Highly flexible
Key Strength	Space savings	Fire resistance	Corrosion under insulation protection

Selecting the right insulation depends on **operating temperature**, **available space**, and **environmental conditions**. Many installations combine materials for optimal performance across varying pipe segments.



WDS Microporous **Superwool PLUS Blanket** **AEROX Blanket**

Engineered Solutions for All Hot Temperatures

Morgan's expanded material range is optimized to deliver the best combination of thermal performance, insulation thickness, and cost across all operating temperatures.

Selection by Temperature Range

- 0-500°C**
Aerogel, WDS® Microporous — Ultra-thin, ultra-low conductivity. Ideal for space-constrained applications.
- 500-900°C**
Hot Face: AES or RCF blanket
Cold Face: Aerogel or WDS Microporous composite layering.
- Above 900°C**
RCF, AES — Refractory ceramic fibre systems for maximum temperature resistance

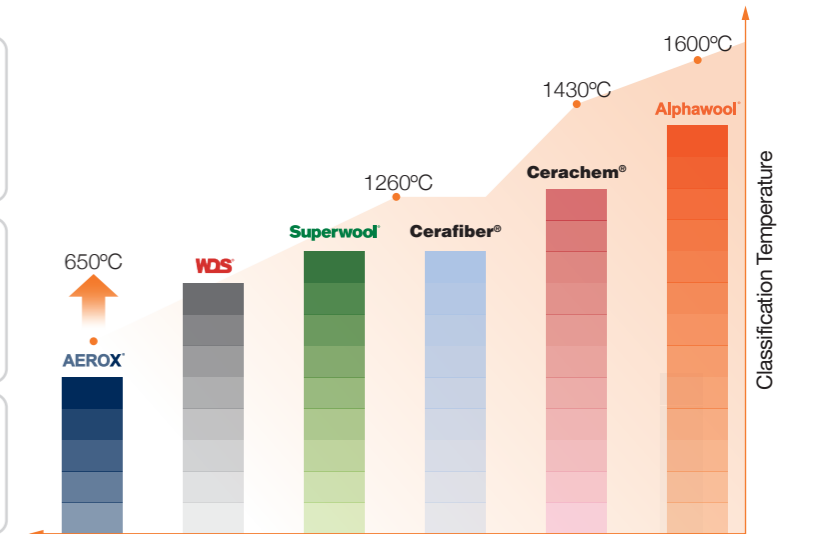

Case Study

Process Temperature: 875°C
Pipe Diameter: 135mm

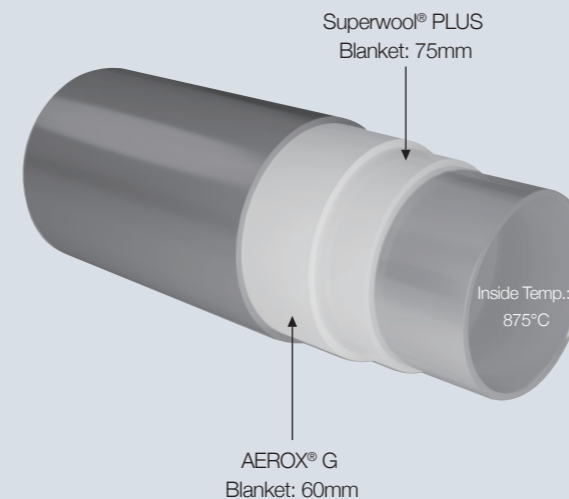

Wall layers from inside to outside	Without AEROX		With AEROX	
	Superwool® PLUS Blanket (128kg/m³)	150mm	Superwool® PLUS Blanket (128kg/m³)	AEROX® G Blanket (180kg/m³)
Lining Design			75mm	60mm
Total Insulation Thickness, mm	150		135	
Outer Surface Temperature, °C	77.5		73.9	

Thinner lining with a lower cold-face temperature using combined insulation materials.

Lightweight, Space-efficient Insulation with Reliable Thermal Performance

Thermal Conductivity Comparison

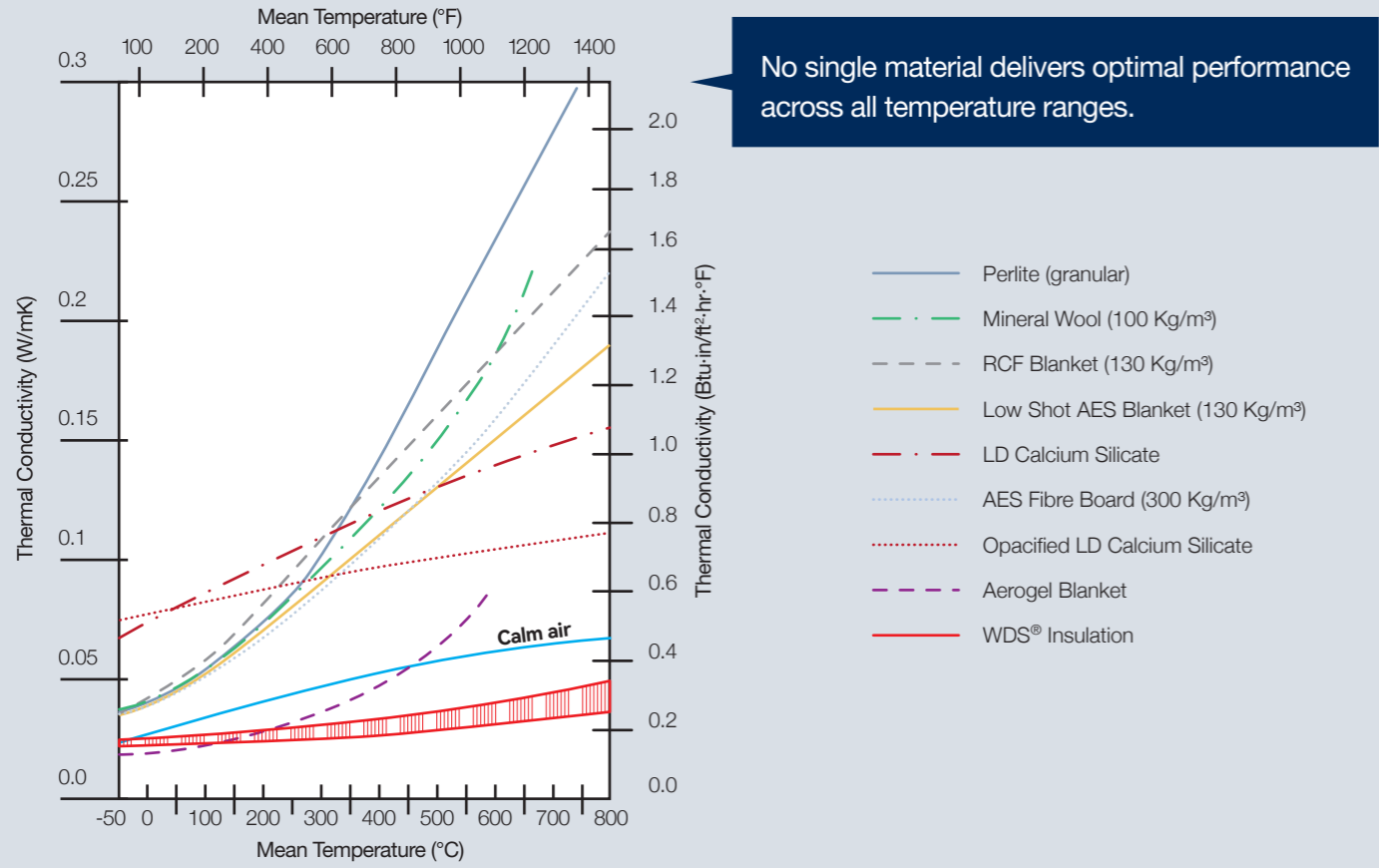

Thickness Comparison of Materials

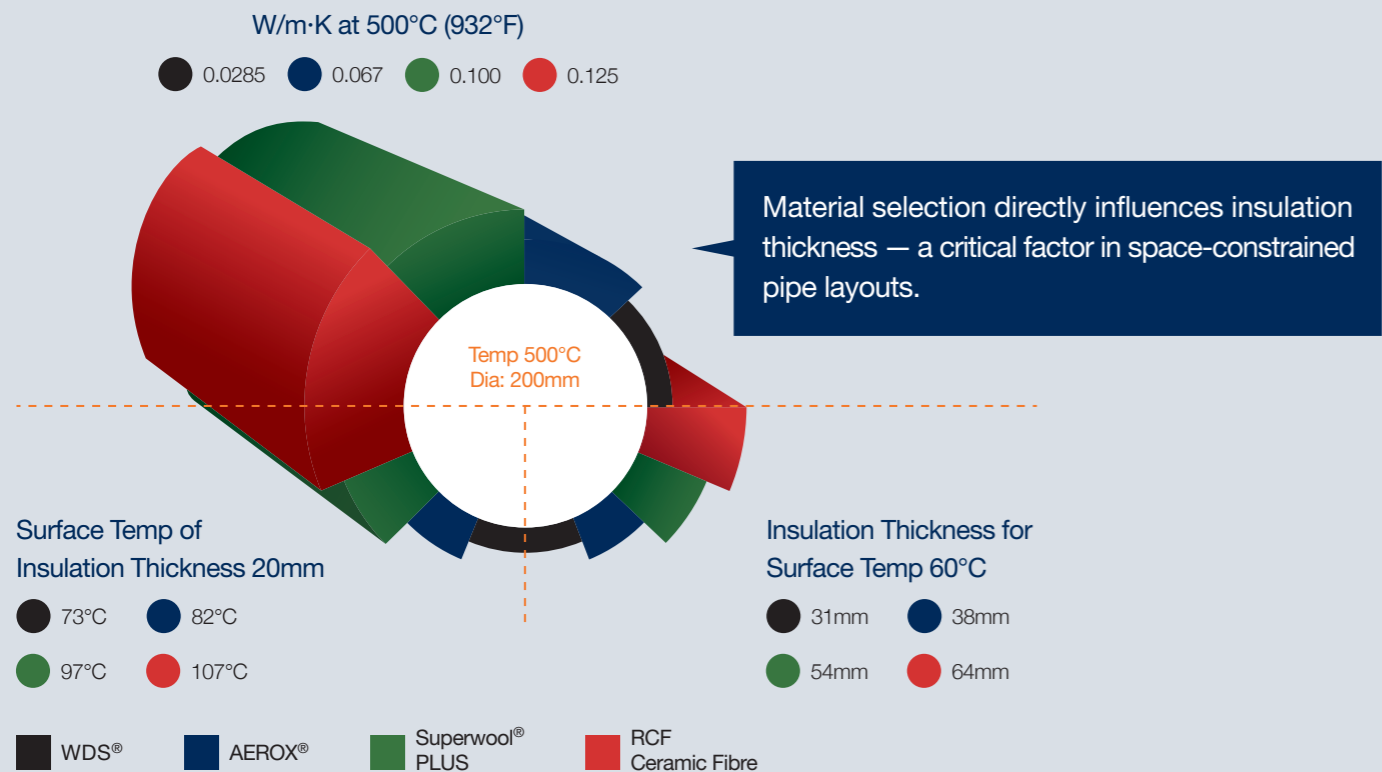

Industrial Applications

Power Generation

Steam mains, superheated steam lines, HRSG piping, turbine inlet/exhaust systems.

Energy & Hydrogen

Reformer piping, thermal oxidizers, hydrogen processing and battery material kiln systems.

Oil & Gas / Refining

Hot process piping, reformer outlet lines, flare headers, furnace/heater transfer lines.

Metals & Heavy Industry

Furnace off-gas piping, combustion air lines, heat treatment systems, kiln and calciner piping.

Chemical Processing

Reactor inlet/outlet piping, distillation systems, high-temperature solvent and polymer lines.



Superwool[®] PLUS Blanket /
WDS Microporous



AEROX[®] Blanket



WDS[®] Microporous

Contact our team to optimize your pipe insulation for performance, space efficiency and lifecycle cost.