

## Pyroscat® Duct Wrap XL



Datasheet Code US: 714-237

© 2014 Thermal Ceramics is a business of Morgan Advanced Materials



### Product Features

- Thin and Lightweight at 1-1/2" (38mm) thick, 6 pcf (96 kg/m<sup>3</sup>) density
- Contours easily to complex duct designs
- Grease duct installation UL and ULC Listed with butt joints at all seams on both layers
- Fully foil encapsulated for fast and clean installation
- Contains 2192°F (1200°C) rated fibers
- Microbial Resistance validated by UL Environment
- Good sound absorption
- Compliant to IMC, NFPA 96, UMC, CMC, CNBC

### 2. Applications

- 2 hour enclosure and firestop system for kitchen exhaust duct
- Zero clearance to combustibles
- 1, 2 and 3 hour enclosure and firestop system for hazardous exhaust ducts, pressurization ducts, clothes dryer exhaust ducts, trash and linen chutes, and other fire rated HVAC ducts
- 1 hour electrical circuit integrity protection
- Engineered and tested solutions for fire protection of structural steel and storage vessels per ASTM E119, ISO 834, and UL1709

### 3. Specifications - Division 23 07 00 (or 15080)

CSI Spec and AutoCAD available online, [www.arcat.com/sd/clients/thermcer.html](http://www.arcat.com/sd/clients/thermcer.html).

Thermal Ceramics Pyroscat Duct Wrap XL is a flexible high temperature insulation rated to 2192°F (1200°C) that is fully encapsulated in FSP facing. The duct enclosure system shall be listed by UL and /or ULC per ASTM E 2336, CAN/ULC S144 and ISO 6944 for 1-, 2- and 3-hour rating and zero clearance to combustibles, and tested per ASTM E84 for a flame/smoke rating less than 25/50. Insulation shall have a nominal thickness of 1-1/2 inches (38 mm) and density of 6 lbs/ft<sup>3</sup> (96 kg/m<sup>3</sup>). Insulation shall have a R-Value of 7.3 at 75°F. Installation shall be in strict accordance to manufacturers published installation instructions, UL or ULC Listings, and shop drawings. FastDoor™ XL shall be used for duct access where specified or as required by code.



\* Commonly referred to test method CA Section 01350 is CDPH Standard Method for the Testing and Evaluation of Volatile Organic Chemical Emissions from Indoor Sources Using Environmental Chambers Version 1.1, Feb 2010

### Grease Duct Enclosure System

### Air Ventilation Duct Enclosure System

### Product Data & Installation Guide

#### 1. Product Description

Thermal Ceramics Pyroscat® Duct Wrap XL is a flexible blanket composed of high temperature fibers classified for applications to 2192°F (1200°C) and fully encapsulated in a durable glass fiber reinforced foil facing for easy handling and installation. Pyroscat Duct Wrap XL is UL and ULC Listed for 1 and 2 hour fire resistive enclosure protection, zero clearance for kitchen exhaust ducts, electrical circuit protection, and as a component in UL firestop designs for fire resistance rated floors, ceilings, and walls. The core fibers in Pyroscat Duct Wrap XL are manufactured using Thermal Ceramics patented Superwool® fiber which is an alkaline-earth silicate wool with low biopersistence and therefore increased safety for installers. Pyroscat Duct Wrap XL is under UL's Follow-Up Service Program to ensure the consistent quality essential to this life-safety application.

## Pyroscat® Duct Wrap XL



### 4. Physical Characteristics

Product	Unit	Size	Units/ Ctn.	Wt./ Ctn.
Pyroscat Duct Wrap XL	Roll	1-1/2" x 24" x 25'	1	37.5 lbs.
Pyroscat Duct Wrap XL	Roll	1-1/2" x 48" x 25'	1	75 lbs.

### 5. Performance Specifications

Reference Standard	Standard No.	Performance
<b>Grease Duct Enclosure System</b>	ASTM E2336	Pass
Section 16.1 - Non-Combustibility	ASTM E136	Pass
Section 16.2-Fire Resistance (wall)	ASTM E119	Pass
Section 16.3 - Durability Test	ASTM C518	Pass
Section 16.4 - Internal Fire Test	ASTM E2336	Pass
Section 16.5 - Fire Engulfment (duct)	ASTM E814/ E119	Pass
ULC Grease Duct Test Protocol		Pass
Standard Methods of Fire Resistance Tests - Grease Duct Assemblies	CAN/ULC S144	Pass
Grease Duct Clearances	UL 1978	Pass
<b>Air Ventilation Duct Enclosure</b>	ISO 6944	Pass
<b>Surface Burning Characteristics</b>	ASTM E84	<25/50
<b>Thermal Resistance (R-value @ 75°F)</b>	ASTM C518	7.3 per layer
<b>Mold Growth</b>	ASTM C1338	ULE Validated
<b>Low VOCs</b>	CA Standard 01350	ULE Validated

### 6. Listings/Building Code Reports

Listed Uses	Agency	Listing	Layers
Grease Duct Enclosure per ASTM E2336 and AC101 (2006, 2009, 2012 IMC, NFPA 96, UMC, CMC)	UL	G18	2
	ICC-ES	ESR 2213	
ULC Grease Duct Test Protocol and CAN/ULC S144*	ULC	FRD 4, 7*	2
Grease Duct Insulation (2003 IMC)	OPL	TC/BI 120-01	1
Through Penetration FireStop System per ASTM E814, UL 1479	UL	See Figure 2	1 or 2
	ULC		
1- or 2-hour Ventilation Duct Enclosure per ISO 6944-1985	UL	HNLJ.V1, 19, 29	1
	ULC	FRD 3, 5, 6, 18	
3-hour Ventilation Duct Enclosure per ISO 6944-1985	UL	HNLJ.V2	2
Electrical Circuit Protective System	UL	FHIT.5	2

### 7. Storage

Thermal Ceramics Pyroscat Duct Wrap XL must be stored in a dry warehouse environment on pallets. Pallets should not be stacked.

### 8. Installation

Thermal Ceramics Pyroscat Duct Wrap XL shall be installed by a qualified contractor in accordance with manufacturer's instructions and laboratory design listings.

#### Materials and Equipment

- Thermal Ceramics Pyroscat Duct Wrap XL blanket
- Aluminum foil tape
- Glass filament reinforced tape (optional)
- Carbon steel or stainless steel banding material, minimum 1/2" (13mm) wide, minimum 0.015" (0.4mm) thick, with steel banding clips
- Hand banding tensioner and crimping tool
- Minimum 12 gage (3mm) steel insulation pins; steel speed clips, minimum 1-1/2" (38mm) square or 1-1/2" (38mm) diameter, or equivalent sized cup-head pins;
- Capacitor discharge stud gun
- Thermal Ceramics FastDoor™ XL
- An approved firestop sealant

## Pyroscat® Duct Wrap XL



### General

Cut edges of the blanket shall be taped with aluminum foil tape to prevent exposed edges of the insulation absorbing grease and moisture in the event of a compromised grease duct joint or condensation. Overlaps and/or tightly butted joints are used to block heat transfer in the event of duct deformation resulting from thermal expansion. Filament tape is suggested to hold the blanket in place until steel banding or pinning is installed to permanently secure the blanket.

### A. Installation on Grease Duct per ASTM E2336 and CAN/ULC S144 (Figure 1)

System requires two layers of insulation applied directly to the duct with tight butt joints at all seams on both layers. The first layer of insulation is cut to a length sufficient to wrap around the duct and provide a tight butt joint where the blanket ends meet. Adjacent blankets on the first layer are butted tightly together with longitudinal seams offset minimum 6" (150mm). The second layer of insulation is installed in the same method as the first layer, with seams between layers offset a minimum of 6" (150mm). Banding and/or pinning per Section D is used to permanently secure the insulation to the duct.

### B. Installation on HVAC Duct per ISO 6944 (Figure 1)

System requires one layer of insulation applied directly to the duct with 3" (75mm) overlaps at all seams. The insulation is cut to a length sufficient to wrap around the duct and provide a 3" (75mm) overlap where the blanket ends meet. Adjacent blankets are installed to provide a minimum overlap of 3" (75mm). Banding and/or pinning per Section D is used to permanently secure the insulation to the duct.

### C. 2 & 3 Sided Wrap Installation (Figure 4)

When space does not allow for a complete wrap applied to the duct on all four sides, the Pyroscat Duct Wrap XL is approved for 2 or 3 sided installations with mechanical attachment to a rated concrete or CMU assembly. (See Figure 4 for installation details.)

### D. Mechanical Attachment Methods

- 1) Banding (Figure 1)** - Minimum 1/2" (13mm) wide carbon steel or stainless steel banding, 0.015" (0.4mm) thick, is placed around the entire perimeter of the insulated duct on maximum 10-1/2" (270mm) centers and 1-1/2" (38mm) from each blanket edge or 1-1/2" (38mm) from each collar edge when using the

butt joint and collar method. The banding is placed around the blanket and tightened to firmly hold the Pyroscat Duct Wrap XL in place against the duct, but not cause any cutting or damage to the blanket.

- 2) Pinning** - Pinning on all sides of the duct may be used as an alternative to banding. For ducts wider than 24" (610mm) pinning is required on the bottom of horizontal runs, or on one side of vertical runs (in addition to steel banding). When applicable, 12 Gage (0.4mm) steel pins are installed on 12" (305mm) centers along the width of the duct and 10-1/2" (270mm) centers along the length of the duct. Pins that extend beyond the outer blanket layer shall be turned down or the excessive length cut off to prevent sharp edges. Shoot through pins (cup head pins) may be used in conjunction with steel banding to prevent blanket sag.

### E. Access Doors

- 1) FastDoor™ XL (Figure 3)** - FastDoor XL is a UL Listed, liquid tight duct cover panel supplied complete with a single layer insulation cover per UL Listing HNK T G18. The FastDoor XL is installed per included installation instructions. No field welding is required.
- 2) Field Fabricated Access Doors** - Each access door assembly has four threaded rods 1/4 inch (6mm) in diameter and 5" (127mm) in length, with one welded to each corner of the door opening. Hollow steel tubes, 4-1/2" (114mm) long are installed outside the access cover plate and over the threaded rods. Four 12 gage (3mm) and 4-1/2" (114mm) long steel insulation pins are welded to the access cover plate to allow for installation of the three layers of Pyroscat Duct Wrap XL. One layer of Pyroscat Duct Wrap XL is cut to approximately the same size as the access panel, and impaled over the insulation pins on the panel. A second layer of Pyroscat Duct Wrap XL is cut so as to overlap the first layer a minimum of 1-1/2" (38mm). It is essential that the first and second layer fit tightly against the surrounding wrap with no through openings. The third and outside layer should be cut to overlap the second insulation layer by a minimum of 1-1/2" (38mm). Minimum 1-1/2" (38mm) round or square insulation clips are installed on the insulation pins to secure the three layers of insulation to the access cover plate.

## Pyroscat® Duct Wrap XL



All cut edges of the insulation shall be taped with minimum 3" (75mm) wide aluminum foil tape. Wing nuts and washers are installed on the four threaded rods, and tightened against the hollow steel tubes to seal the access cover plate to the duct.

### F. Through Penetration Firestop System (Figure 2) -

When the duct penetrates a fire rated assembly an approved fire stop system must be employed. Figure 2 provides a complete list of UL / ULC firestop design listings which can be found in the Certifications Directory at [www.ul.com](http://www.ul.com) for US systems and [www.ulc.ca](http://www.ulc.ca) for Canadian systems. Prior to installing any firestop system the surfaces of all openings and penetrating items must be clean and dry. The Pyroscat Duct Wrap XL core blanket (or mineral wool where allowed by the firestop design listing) must be compressed into the annular space. The packing material must be recessed a minimum depth from the surface of the concrete or gypsum assembly. The recessed opening must be filled with a minimum thickness of an approved firestop sealant. The packing material type and compression, minimum recess (typically 1/4" (6mm)), and approved firestop sealant and thickness (typically 1/4" (6mm)) shall be as specified in an approved UL / ULC firestop design listing. When there is not sufficient annular space around the duct to run the Pyroscat Duct Wrap XL enclosure system continuous through the fire rated assembly, the enclosure may terminate above and below the floor/ceiling assembly or on either side of a wall assembly as shown in Figure 2. When this method is used, the Pyroscat Duct Wrap XL must be mechanically attached on either side of the fire rated assembly using one of the attachment methods described in Section D, spaced a maximum of 1-1/2" (38mm) from the fire rated assembly.

### G. Support Hanger Systems

**1) Grease ducts:** Trapeze support hangers shall be spaced on maximum 60 in. (1500 mm) centers. Hanger rods or straps shall be anchored with steel drop in or wedge expansion type masonry anchors. No additional protection is required for hangers and supports meeting the requirements of the Table below.

Hanger Cross Section	Maximum Perimeter, in (mm)	Trapeze Support (or equivalent Yield Strength), in (mm)
3/8 in (10 mm) threaded rod	148 (3759)	2 (51) x 2 (51) x 1/8 (3) in angle

**2) HVAC ducts:** Trapeze support hangers shall be spaced on maximum 60 in. (1500 mm) centers. Hanger rods or

straps shall be anchored with steel drop in or wedge expansion type masonry anchors. No additional protection is required for hangers and supports meeting the requirements of the Table below.

Hanger Cross Section	Max. Perimeter, in (mm)	Trapeze Support (or equivalent Yield Strength), in (mm)
1 in x 16 gage strap (25 mm x 1.5 gage strap)	100 (2540)	
1/4 in (6 mm) threaded rod	50 (1270)	1 1/2 (38) x 1 1/2 (38) x 3/16 (5) angle
3/8 in (10 mm) threaded rod	150 (3810)	1 1/2 (38) x 1 1/2 (38) x 3/16 (5) angle
1/2 in (12.7 mm) threaded rod	218 (5540)	2 (51) x 2 (51) x 1/4 (6) angle

### 9. Maintenance and Repair

No maintenance is required when installed in accordance with Thermal Ceramics (TC) installation instructions. If damage is limited to the foil facing, aluminum foil tape can be used to repair the foil facing. If an area of blanket is found to be damaged the following procedure must be incorporated. If the damaged area is larger than 8" (203mm) x 8" (203mm) the entire wrap section must be removed and replaced according to TC installation instructions. If the damaged area is small (less than 8" (203mm) x 8" (203mm)), the damaged area must be cut away and replaced with a new section 1" (25mm) larger in length and width than the cut out, such that the new section can be compressed tightly into the cut out area. All cut edges of the new section must be taped and sealed with aluminum foil tape. The new section must be held in place with either pinning or banding per TC installation instructions.

### 10. Limitations

Thermal Ceramics Pyroscat Duct Wrap XL shall be installed in accordance with these installation instructions and appropriate laboratory design listings. The integrity of Pyroscat Duct Wrap XL systems is limited to the quality of the installation.

\* For personal protective equipment recommendations, please see SDS.

Thermal Ceramics and Pyroscat are trademarks of Morgan Advanced Materials. Pyroscat products are manufactured by Thermal Ceramics and are distributed by authorized distributors.



Grease and HVAC Duct Enclosure System  
1 or 2 Hour Shaft Alternative / Zero Clearance to Combustibles

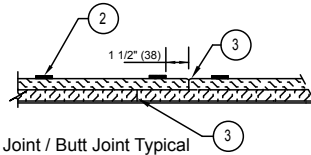
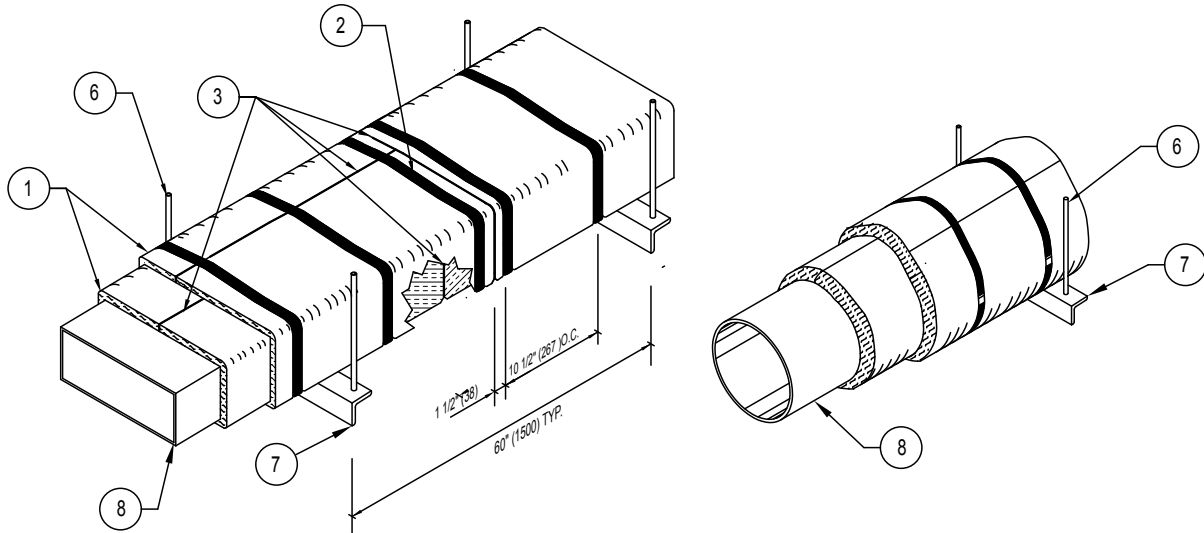

TWO LAYER INSTALLATION (Grease Duct per ASTM E2336 and CAN/ULC S144)

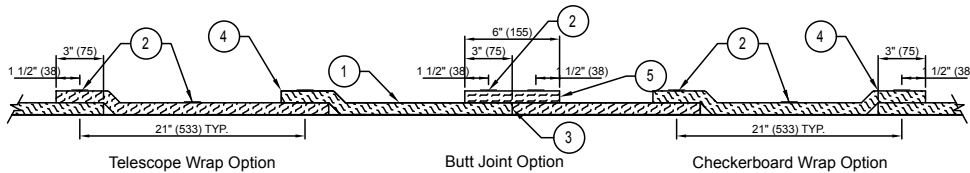

SINGLE LAYER INSTALLATION OPTIONS (2-Hour rated HVAC Duct per UL HNLJ V-19)

LEGEND	
1	Two Layers of XL Insulation for ASTM E2336 and CAN/ULC S144 Grease Duct Enclosures One Layer of XL Insulation for 2-Hour Air Ventilation Duct Enclosures
2	Steel banding minimum 1/2" (13) wide by 0.015" (0.4) thick.
3	Tight butt joints (no overlap) at perimeter and longitudinal joints, both layers for grease ducts
4	Min. 3" (75) overlap on perimeter and between adjacent blankets
5	Optional 6" XL collar
6	Hangers - size dependent weight of assembly (see datasheet Section G)
7	Trapeze Supports - size dependent on weight of assembly (see datasheet Section G)
8	Steel Rectangular or Round Duct (size, gage and construction dependent per Listed Design)

The integrity of Thermal Ceramics duct systems is limited to the quality of the installation.

XL001-10



Commercial Kitchen Grease Duct Enclosure System  
Air Ventilation Duct Enclosure System  
Through Penetration Firestop Systems

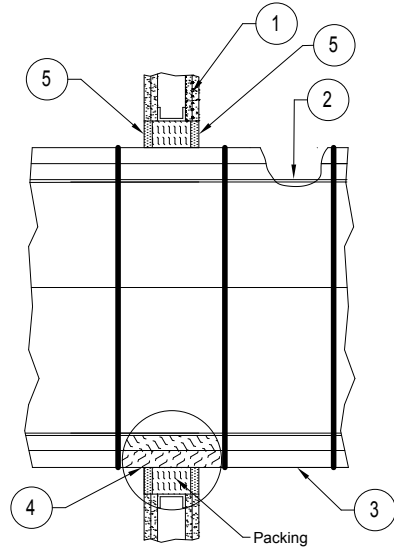

XL Insulation continuous through rated wall assembly

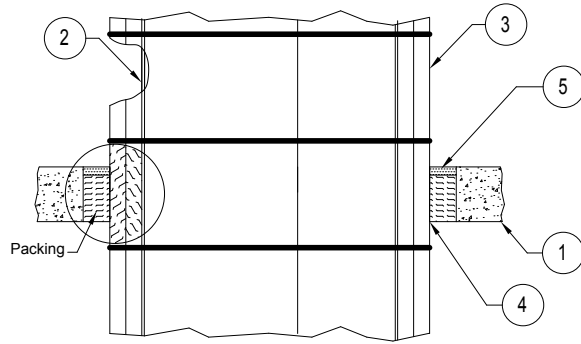

XL Insulation continuous through rated floor/ceiling assembly

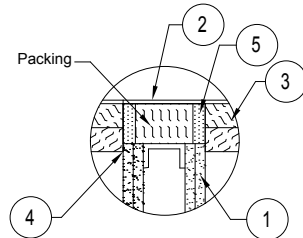

XL insulation terminated on both sides of the rated wall assembly

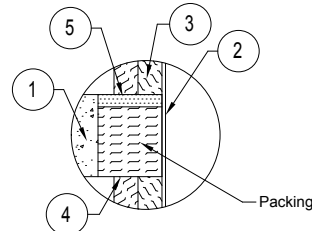

XL insulation terminated at the top and bottom surface of the floor/ceiling assembly

Firestop Designs per ASTM E814 / UL 1479 - Consult UL / ULC Directories for System Details

UL Listing	F- & T-Rating	(1) Floor/Wall	(2) Penetrant	(3) Enclosure Per	(4) Termination	(5) Firestop Sealant Details
C-AJ-7012	2-hour	Concrete/CMU	84x24; 26 Ga Duct	V19; FRD3; 5; 18	wrap through	1/2 in; STI; Tremco
C-AJ-7014	3-hour	Concrete/CMU	84x24; 26 Ga Duct	V2;	wrap through	1/2 in; STI; Tremco
C-AJ-7019	1 or 2-hour	Concrete/CMU	84x24; 26 Ga Duct	V19; FRD3; 5, 18	terminate at	1/4 in; STI; Tremco
C-AJ-7021	2-hour	Concrete/CMU	49x24; 16 Ga Duct	G18; FRD4; 7	terminate at	1/4 in; STI; Tremco
C-AJ-7095	2-hour	Concrete/CMU	39x39; 22 Ga Duct	V19; FRD3; 5, 18	wrap through	1/4 in; STI; Hilti; Rectorseal; Tremco
C-AJ-7098	2-hour	Concrete/CMU	49x24; 16 Ga Duct	G18; FRD4; 7	wrap through	1/4 in; STI; Hilti; Rectorseal; Tremco
F-C-7036	1 or 2-hour	Wood/Gyp Floor	24x12; 16 Ga Duct	G18; FRD4; 7	wrap through	1/4 in; STI; Hilti; Rectorseal; Tremco
F-C-7055	1-hour	Wood/Gyp Floor	4 Dia; 30 Ga Duct	V29; FRD28	wrap through	1/4 in; STI
W-J-7086	2-hour	Concrete/CMU Wall	100x100; 26 Ga Duct	V19; FRD3;5; 18	terminate at	1/4 in; STI
W-L-7121	1 or 2-hour	Gyp Wall	30x30; 16 Ga Duct	G18; FRD4; 7	wrap through	1/4 in; STI; Hilti; Rectorseal; Tremco
W-L-7145	1 or 2-hour	Gyp Wall	100x100; 26 Ga Duct	V19; FRD3; 5; 18	terminate at	5/8 in; STI

The integrity of Thermal Ceramics duct systems is limited to the quality of the installation.  
XL003-5

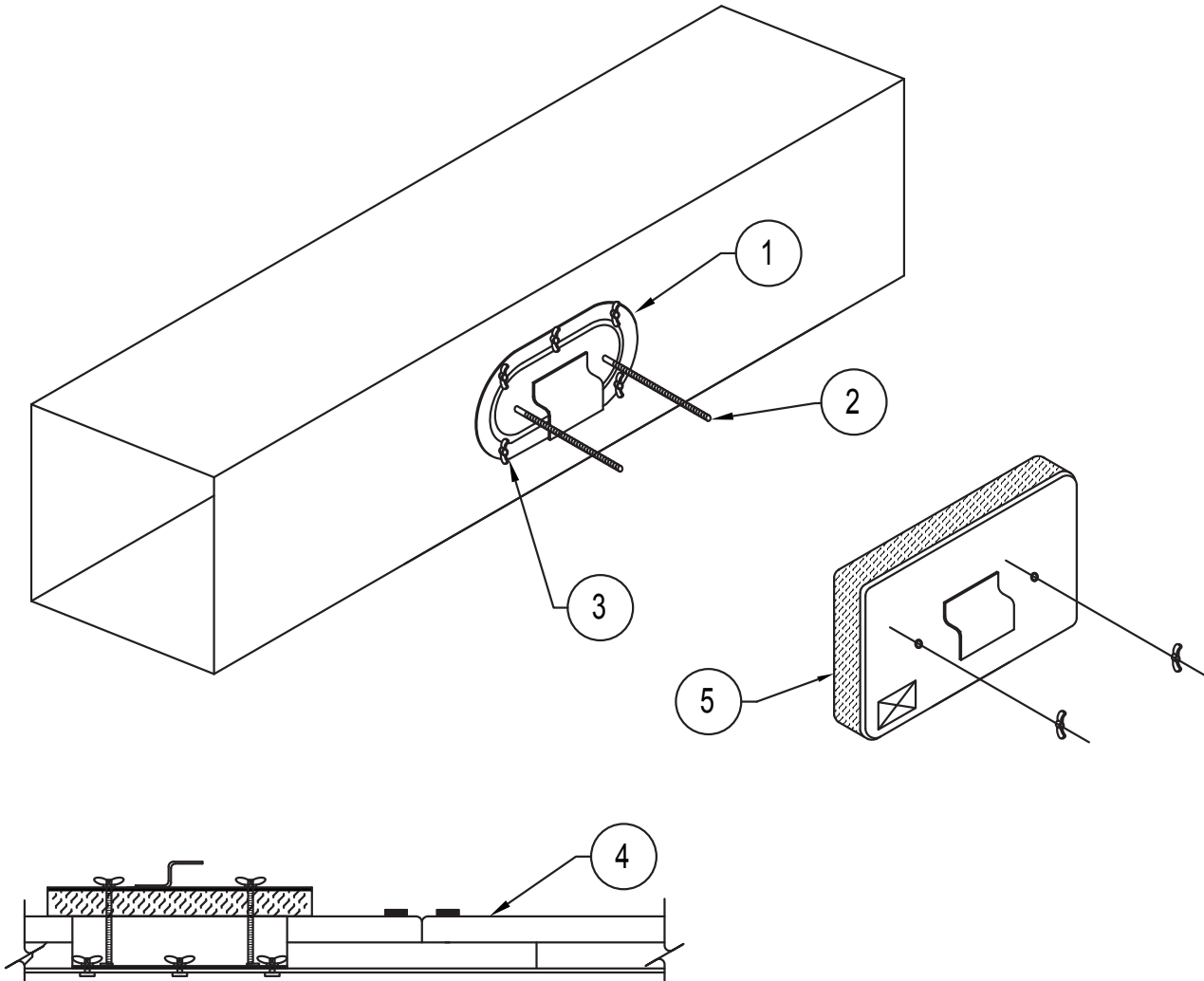

ASTM E 2336 Compliant Enclosure and Door System

FIGURE 3	
1	UL listed FastDoor XL access panel
2	All Thread Rods and wing nuts
3	Retainer Clips with threaded nut and wing bolts
4	Insulation layers as required by UL or ITS Listings
5	FastDoor XL; 1-1/2 inch thick single layer insulation

FastDoor XL1 Access Doors Sizes	
Available Opening Sizes	Ordering Code
10" x 4" Door Opening	*434-6970-033-99X1
10" x 6" Door Opening	434-6970-034-99X1
12" x 8" Door Opening	434-6970-035-99X1
12" x 12" Door Opening	434-6970-036-99X1
16" x 12" Door Opening	434-6970-037-99X1
20" x 20" Door Opening	434-6970-038-99X1
*Special Order; Curved and SS Available	



Commercial Kitchen Grease Duct Enclosure System  
Air Ventilation Duct Enclosure System

1 Or 2 Or 3 Hour Shaft Alternative / Zero Clearance to Combustibles  
2 and 3 Sided Wrap Detail for Attaching to Walls and/or Ceilings

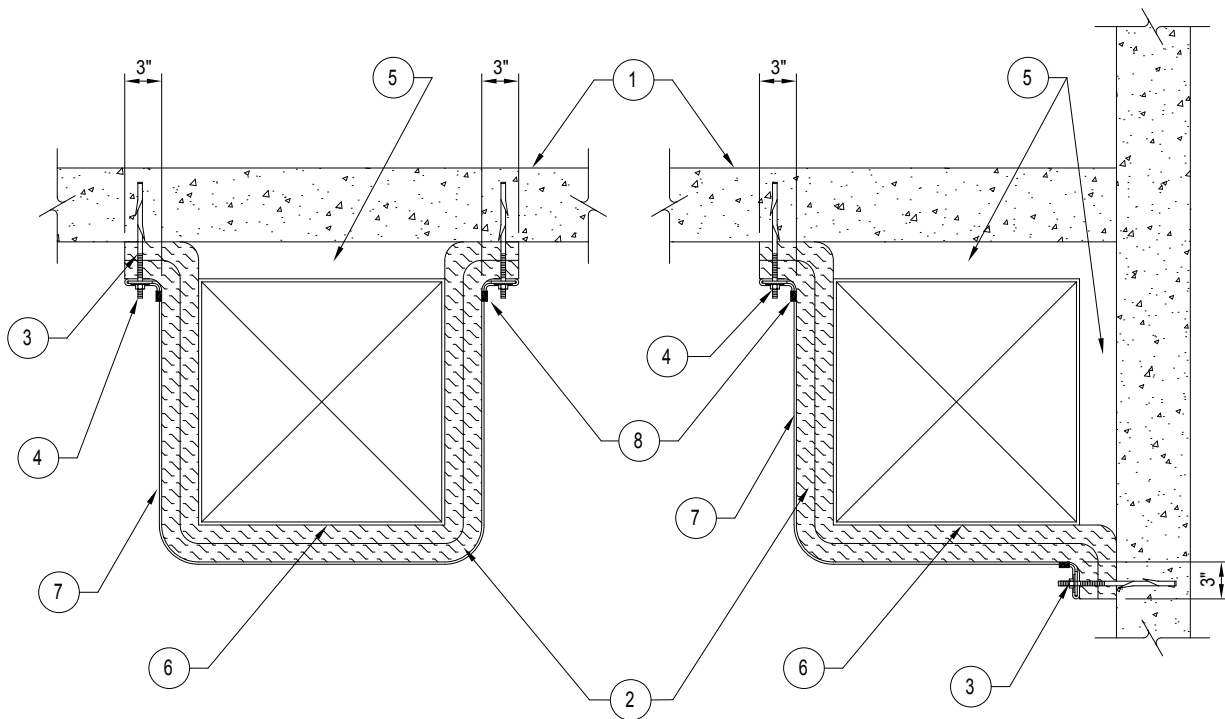

Note: Ducts must be independently supported per code

LEGEND	
1	Rated Concrete floor/ceiling, or wall - with rating equal or greater than enclosure rating
2	Two layers of XL Insulation for Grease Duct Enclosures (install per UL G18) One layer of XL Insulation for Air Ventilation Duct Enclosures (install per UL V19) Two layers of XL Insulation for 3-hr Air Ventilation Duct Enclosure (install per UL V2)
3	Concrete fastener system
4	3/16" (5) thick x 2" (50) -3" (75) wide bar stock perforated 12" (305) o.c.
5	8" (203) maximum Air Gap
6	Duct
7	Steel banding min. 1/2" (13) wide by 0.015" (0.4) thick.
8	Banding clip

The integrity of Morgan Thermal Ceramics duct systems is limited to the quality of the installation.